



**OVERVIEW**

The Agree Table was created to support the evolving needs of upper-grade classrooms, CTE spaces, and higher education environments. As instruction becomes more collaborative, technology-rich, and student-driven, the Agree Table provides a clean, professional foundation that adapts to how learning happens today, while signaling a more adult, high aesthetic experience for students.

**MATERIALS**

High-pressure laminate (HPL) worksurfaces are 1-1/8" (30mm) nominal finished thickness and feature balanced construction to prevent bowing or warping, with 0.028 inch (.71mm) thick high-pressure laminate on the top surface and a resin backer on the bottom. The particleboard wood core is 45 lb/cu ft (720.8 kg/cu m) density. The laminate and backer are permanently attached with PVA adhesive and reinforced under pressure to the wood core. 1/8" (3mm) thick plastic edgeband is applied to the entire perimeter of the worksurface to prevent any outgassing from exposed wood core. T-mold also available.

Formed tubular steel leg is 1-1/2" (40mm) dia. x 13 ga. (.095" or 2mm nom.) welded to a 5-1/2" (140mm) x 6-1/16" (154.5mm) mounting plate of 3/16" thick (4.7mm) thick steel. Optional 3" (68.6mm) dual wheel swivel casters.

**AGREE TOP & EDGE PROFILE**

1 1/4" TOP W/ BUMPER T-MOLD  
NO LETTER TO FOLLOW MODEL NO.

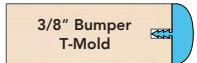

1 1/4" TOP W/ 3MM - 90° CORNERS  
H

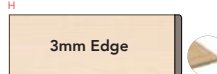

1 1/4" TOP W/ 4MM T-MOLD  
D

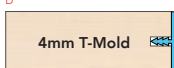

1 1/4" TOP W/ 3MM - ROUND CORNERS  
F

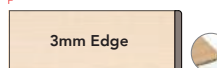

**DIMENSIONS**

Model	Description	D"	W"	H"
02501	20"x34" Rectangle Table	20	34	28.5
02501F	20"x34" Rectangle Table w/ 3mm Edgeband	20	34	28.5

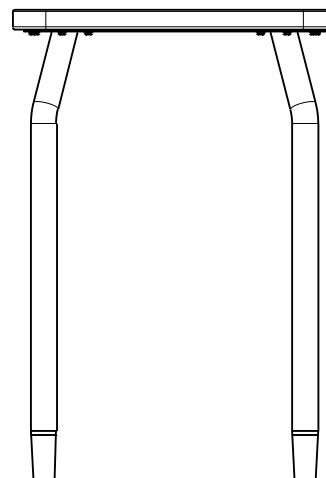
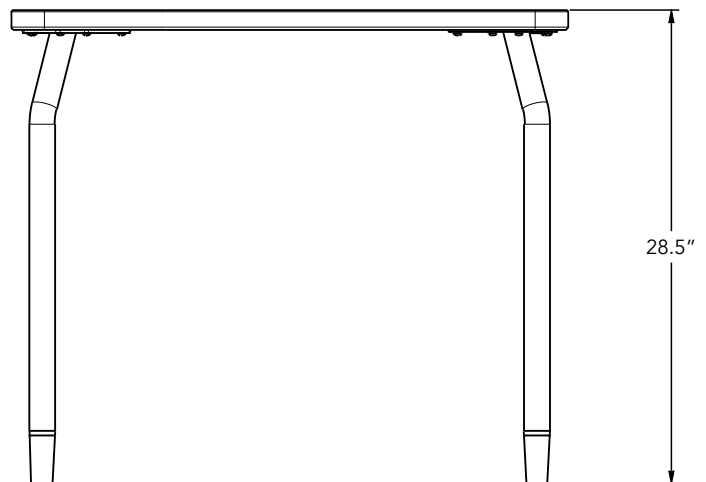
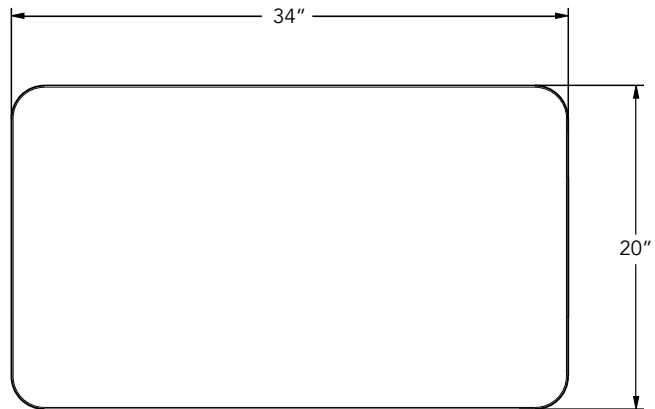

**STANDARD LAMINATE OPTIONS**

Want to specify a different laminate?

No problem. If you have 20 or more tops of the same color -60 or -38 there is no upcharge. Have 20 or less? We can quote for you with the Wilsonart code and finish style. We can specify other laminates – call to inquire and get a quote.



**SUGGESTED LAMINATE OPTIONS**



**STANDARD EDGE COLOR OPTIONS**



All 20 of the standard laminates are -60 finish, if you need to match a laminate from a previous year, please let us know on your order (example Pewter Mesh 4878-38, our standard is -60).

When the WilsonArt Laminate code includes a "Y", "K", "-12" "-78", "Aeon" etc, these are special laminates with an upcharge, even when it contains -38 or -60.

**EDGE COLOR OPTIONS WITH ADDITIONAL LEAD TIME**



**LEG COLOR OPTIONS**





**OVERVIEW**

The Agree Table was created to support the evolving needs of upper-grade classrooms, CTE spaces, and higher education environments. As instruction becomes more collaborative, technology-rich, and student-driven, the Agree Table provides a clean, professional foundation that adapts to how learning happens today, while signaling a more adult, high aesthetic experience for students.

**MATERIALS**

High-pressure laminate (HPL) worksurfaces are 1-1/8" (30mm) nominal finished thickness and feature balanced construction to prevent bowing or warping, with 0.028 inch (.71mm) thick high-pressure laminate on the top surface and a resin backer on the bottom. The particleboard wood core is 45 lb/cu ft (720.8 kg/cu m) density. The laminate and backer are permanently attached with PVA adhesive and reinforced under pressure to the wood core. 1/8" (3mm) thick plastic edgeband is applied to the entire perimeter of the worksurface to prevent any outgassing from exposed wood core. T-mold also available.

Formed tubular steel leg is 1-1/2" (40mm) dia. x 13 ga. (.095" or 2mm nom.) welded to a 5-1/2" (140mm) x 6-1/16" (154.5mm) mounting plate of 3/16" thick (4.7mm) thick steel. Optional 3" (68.6mm) dual wheel swivel casters.

**DIMENSIONS**

Model	Description	D"	W"	H"
02502	20"x48" Rectangle Table	20	48	28.5
02502F	20"x48" Rectangle Table w/ 3mm Edgeband	20	48	28.5

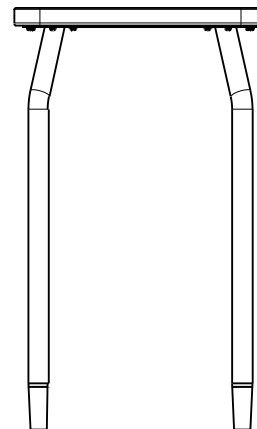
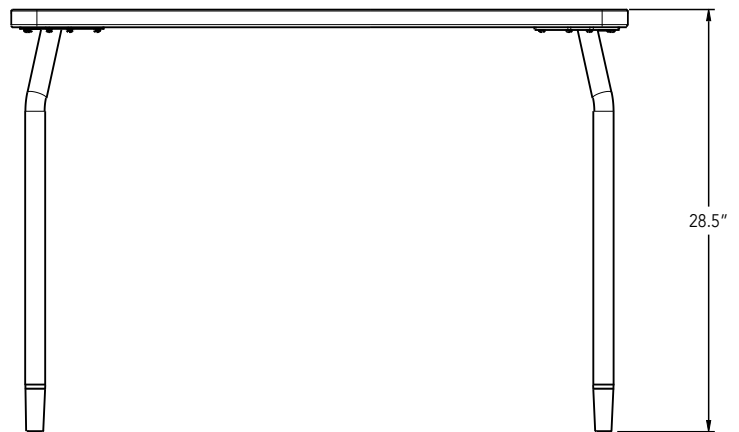
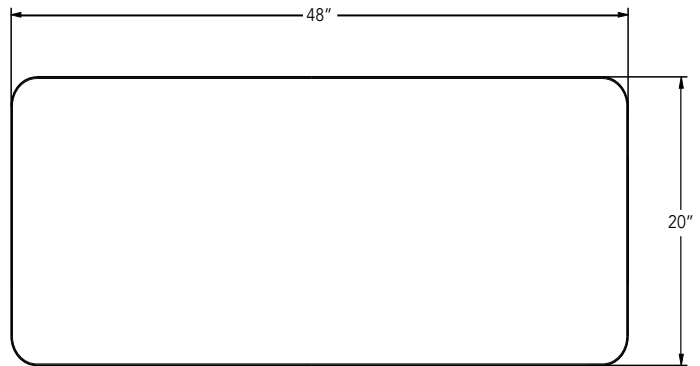

**AGREE TOP & EDGE PROFILE**

1 1/4" TOP W/ BUMPER T-MOLD  
NO LETTER TO FOLLOW MODEL NO.

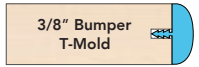

1 1/4" TOP W/ 3MM - 90° CORNERS  
H



1 1/4" TOP W/ 4MM T-MOLD  
D

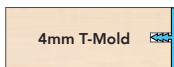

1 1/4" TOP W/ 3MM - ROUND CORNERS  
F

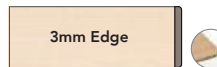



**OVERVIEW**

The Agree Table was created to support the evolving needs of upper-grade classrooms, CTE spaces, and higher education environments. As instruction becomes more collaborative, technology-rich, and student-driven, the Agree Table provides a clean, professional foundation that adapts to how learning happens today, while signaling a more adult, high aesthetic experience for students.

**MATERIALS**

High-pressure laminate (HPL) worksurfaces are 1-1/8" (30mm) nominal finished thickness and feature balanced construction to prevent bowing or warping, with 0.028 inch (.71mm) thick high-pressure laminate on the top surface and a resin backer on the bottom. The particleboard wood core is 45 lb/cu ft (720.8 kg/cu m) density. The laminate and backer are permanently attached with PVA adhesive and reinforced under pressure to the wood core. 1/8" (3mm) thick plastic edgeband is applied to the entire perimeter of the worksurface to prevent any outgassing from exposed wood core. T-mold also available.

Formed tubular steel leg is 1-1/2" (40mm) dia. x 13 ga. (.095" or 2mm nom.) welded to a 5-1/2" (140mm) x 6-1/16" (154.5mm) mounting plate of 3/16" thick (4.7mm) thick steel. Optional 3" (68.6mm) dual wheel swivel casters.

**AGREE TOP & EDGE PROFILE**

1 ¼" TOP W/ BUMPER T-MOLD  
NO LETTER TO FOLLOW MODEL NO.

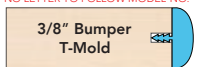

1 ¼" TOP W/ 4MM T-MOLD  
D

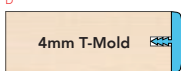

1 ¼" TOP W/ 3MM - 90° CORNERS  
H

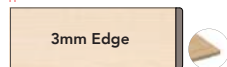

1 ¼" TOP W/ 3MM - ROUND CORNERS  
F

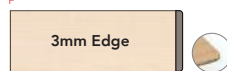

**DIMENSIONS**

Model	Description	D"	W"	H"
02503	20"x60" Rectangle Table	20	60	28.5
02503F	20"x60" Rectangle Table w/ 3mm Edgeband	20	60	28.5

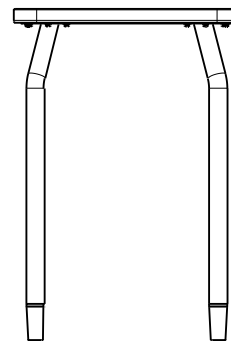
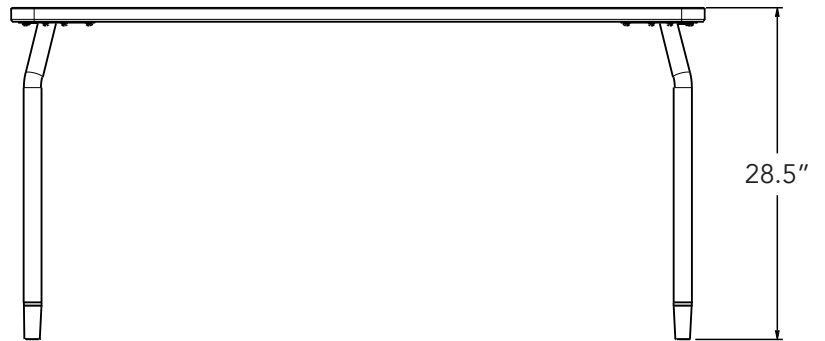
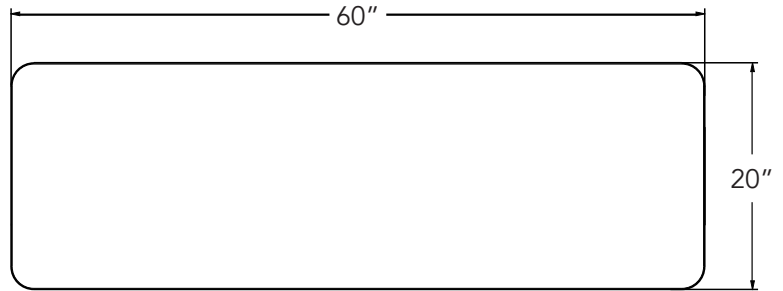



**OVERVIEW**

The Agree Table was created to support the evolving needs of upper-grade classrooms, CTE spaces, and higher education environments. As instruction becomes more collaborative, technology-rich, and student-driven, the Agree Table provides a clean, professional foundation that adapts to how learning happens today, while signaling a more adult, high aesthetic experience for students.

**MATERIALS**

High-pressure laminate (HPL) worksurfaces are 1-1/8" (30mm) nominal finished thickness and feature balanced construction to prevent bowing or warping, with 0.028 inch (.71mm) thick high-pressure laminate on the top surface and a resin backer on the bottom. The particleboard wood core is 45 lb/cu ft (720.8 kg/cu m) density. The laminate and backer are permanently attached with PVA adhesive and reinforced under pressure to the wood core. 1/8" (3mm) thick plastic edgeband is applied to the entire perimeter of the worksurface to prevent any outgassing from exposed wood core. T-mold also available.

Formed tubular steel leg is 1-1/2" (40mm) dia. x 13 ga. (.095" or 2mm nom.) welded to a 5-1/2" (140mm) x 6-1/16" (154.5mm) mounting plate of 3/16" thick (4.7mm) thick steel. Optional 3" (68.6mm) dual wheel swivel casters.

**AGREE TOP & EDGE PROFILE**

1 1/4" TOP W/ BUMPER T-MOLD  
NO LETTER TO FOLLOW MODEL NO.

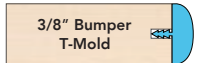

1 1/4" TOP W/ 4MM T-MOLD  
D

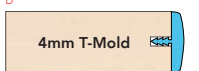

1 1/4" TOP W/ 3MM - 90° CORNERS  
H

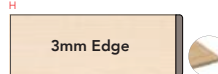

1 1/4" TOP W/ 3MM - ROUND CORNERS  
F

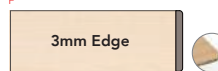

**DIMENSIONS**

Model	Description	D"	W"	H"
02505	24"x34" Rectangle Table	24	34	28.5
02505F	24"x34" Rectangle Table w/ 3mm Edgeband	24	34	28.5

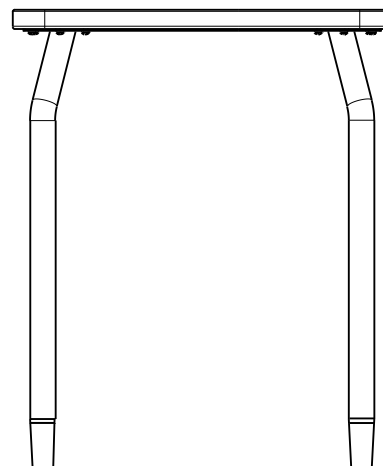
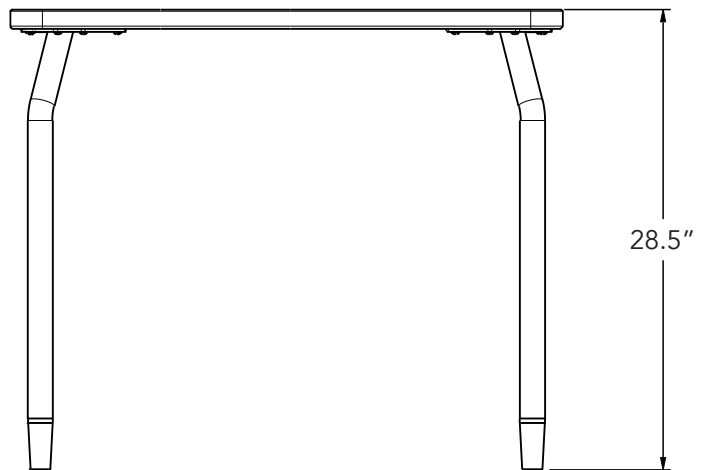
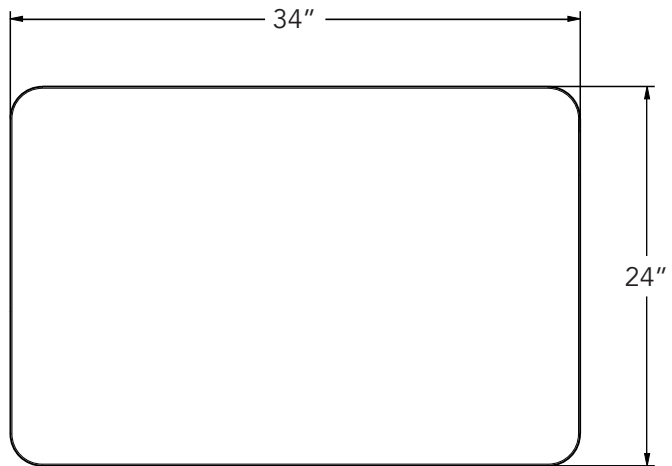



**OVERVIEW**

The Agree Table was created to support the evolving needs of upper-grade classrooms, CTE spaces, and higher education environments. As instruction becomes more collaborative, technology-rich, and student-driven, the Agree Table provides a clean, professional foundation that adapts to how learning happens today, while signaling a more adult, high aesthetic experience for students.

**MATERIALS**

High-pressure laminate (HPL) worksurfaces are 1-1/8" (30mm) nominal finished thickness and feature balanced construction to prevent bowing or warping, with 0.028 inch (.71mm) thick high-pressure laminate on the top surface and a resin backer on the bottom. The particleboard wood core is 45 lb/cu ft (720.8 kg/cu m) density. The laminate and backer are permanently attached with PVA adhesive and reinforced under pressure to the wood core. 1/8" (3mm) thick plastic edgeband is applied to the entire perimeter of the worksurface to prevent any outgassing from exposed wood core. T-mold also available.

Formed tubular steel leg is 1-1/2" (40mm) dia. x 13 ga. (.095" or 2mm nom.) welded to a 5-1/2" (140mm) x 6-1/16" (154.5mm) mounting plate of 3/16" thick (4.7mm) thick steel. Optional 3" (68.6mm) dual wheel swivel casters.

**AGREE TOP & EDGE PROFILE**

1 1/4" TOP W/ BUMPER T-MOLD  
NO LETTER TO FOLLOW MODEL NO.

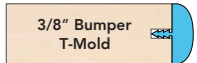

1 1/4" TOP W/ 3MM - 90° CORNERS  
H

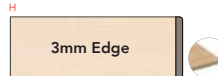

1 1/4" TOP W/ 4MM T-MOLD  
D

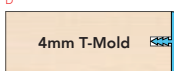

1 1/4" TOP W/ 3MM - ROUND CORNERS  
F

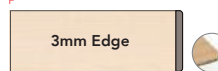

**DIMENSIONS**

Model	Description	D"	W"	H"
02506	24"x40" Rectangle Table	24	40	28.5
02506F	24"x40" Rectangle Table w/ 3mm Edgeband	24	40	28.5

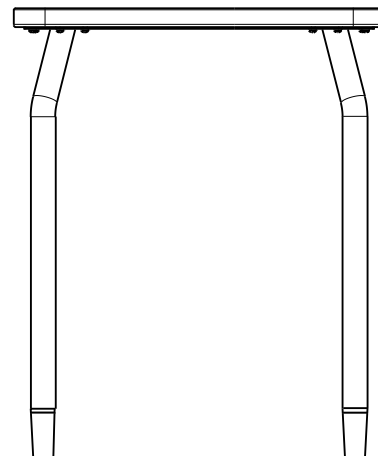
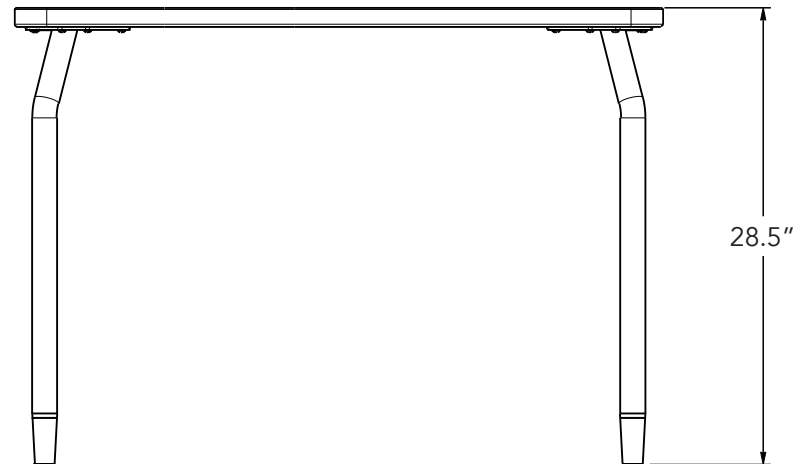
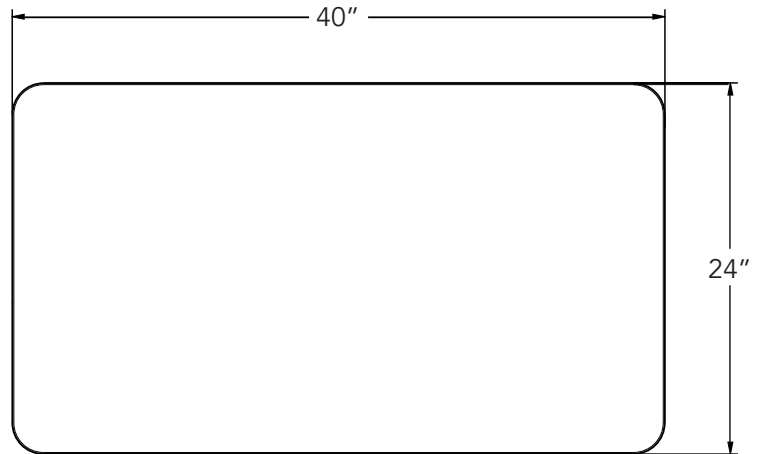



**OVERVIEW**

The Agree Table was created to support the evolving needs of upper-grade classrooms, CTE spaces, and higher education environments. As instruction becomes more collaborative, technology-rich, and student-driven, the Agree Table provides a clean, professional foundation that adapts to how learning happens today, while signaling a more adult, high aesthetic experience for students.

**MATERIALS**

High-pressure laminate (HPL) worksurfaces are 1-1/8" (30mm) nominal finished thickness and feature balanced construction to prevent bowing or warping, with 0.028 inch (.71mm) thick high-pressure laminate on the top surface and a resin backer on the bottom. The particleboard wood core is 45 lb/cu ft (720.8 kg/cu m) density. The laminate and backer are permanently attached with PVA adhesive and reinforced under pressure to the wood core. 1/8" (3mm) thick plastic edgeband is applied to the entire perimeter of the worksurface to prevent any outgassing from exposed wood core. T-mold also available.

Formed tubular steel leg is 1-1/2" (40mm) dia. x 13 ga. (.095" or 2mm nom.) welded to a 5-1/2" (140mm) x 6-1/16" (154.5mm) mounting plate of 3/16" thick (4.7mm) thick steel. Optional 3" (68.6mm) dual wheel swivel casters.

**AGREE TOP & EDGE PROFILE**

1 ¼" TOP W/ BUMPER T-MOLD  
NO LETTER TO FOLLOW MODEL NO.



1 ¼" TOP W/ 3MM - 90° CORNERS  
H



1 ¼" TOP W/ 4MM T-MOLD  
D

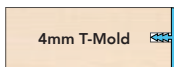

1 ¼" TOP W/ 3MM - ROUND CORNERS  
F

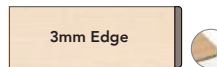

**DIMENSIONS**

Model	Description	D"	W"	H"
02507	24"x48" Rectangle Table	24	48	28.5
02507F	24"x48" Rectangle Table w/ 3mm Edgeband	24	48	28.5

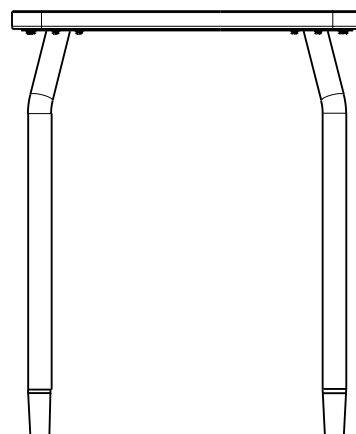
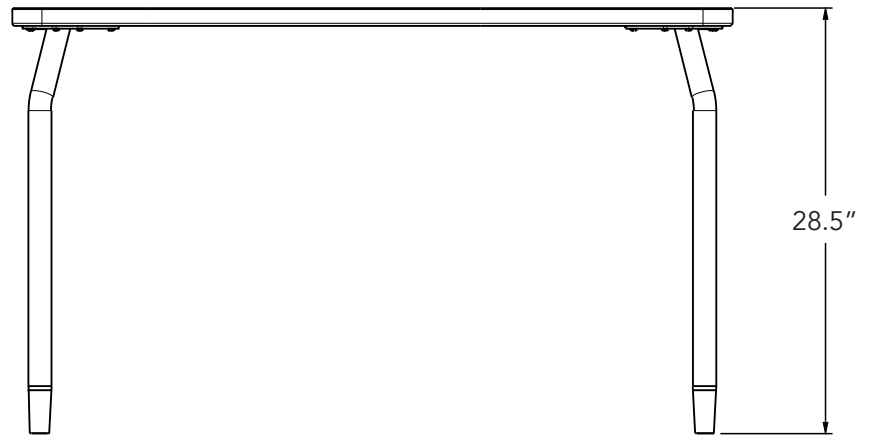
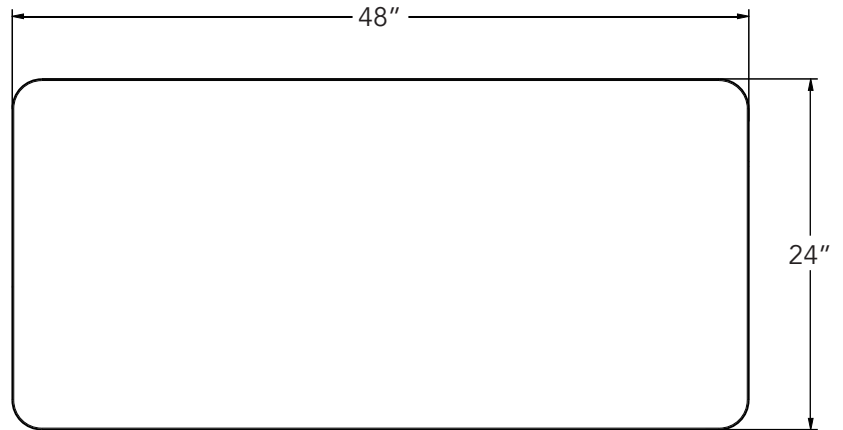



**OVERVIEW**

The Agree Table was created to support the evolving needs of upper-grade classrooms, CTE spaces, and higher education environments. As instruction becomes more collaborative, technology-rich, and student-driven, the Agree Table provides a clean, professional foundation that adapts to how learning happens today, while signaling a more adult, high aesthetic experience for students.

**MATERIALS**

High-pressure laminate (HPL) worksurfaces are 1-1/8" (30mm) nominal finished thickness and feature balanced construction to prevent bowing or warping, with 0.028 inch (.71mm) thick high-pressure laminate on the top surface and a resin backer on the bottom. The particleboard wood core is 45 lb/cu ft (720.8 kg/cu m) density. The laminate and backer are permanently attached with PVA adhesive and reinforced under pressure to the wood core. 1/8" (3mm) thick plastic edgeband is applied to the entire perimeter of the worksurface to prevent any outgassing from exposed wood core. T-mold also available.

Formed tubular steel leg is 1-1/2" (40mm) dia. x 13 ga. (.095" or 2mm nom.) welded to a 5-1/2" (140mm) x 6-1/16" (154.5mm) mounting plate of 3/16" thick (4.7mm) thick steel. Optional 3" (68.6mm) dual wheel swivel casters.

**AGREE TOP & EDGE PROFILE**

1 ¼" TOP W/ BUMPER T-MOLD  
NO LETTER TO FOLLOW MODEL NO.



1 ¼" TOP W/ 4MM T-MOLD  
D

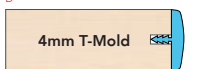

1 ¼" TOP W/ 3MM - 90° CORNERS  
H

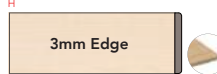

1 ¼" TOP W/ 3MM - ROUND CORNERS  
F



**DIMENSIONS**

Model	Description	D"	W"	H"
02508	24"x60" Rectangle Table	24	60	28.5
02508F	24"x60" Rectangle Table w/ 3mm Edgeband	24	60	28.5

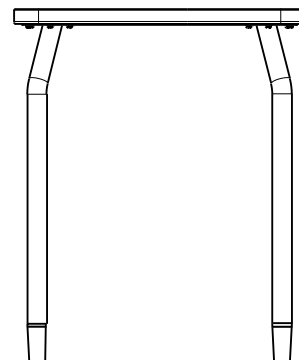
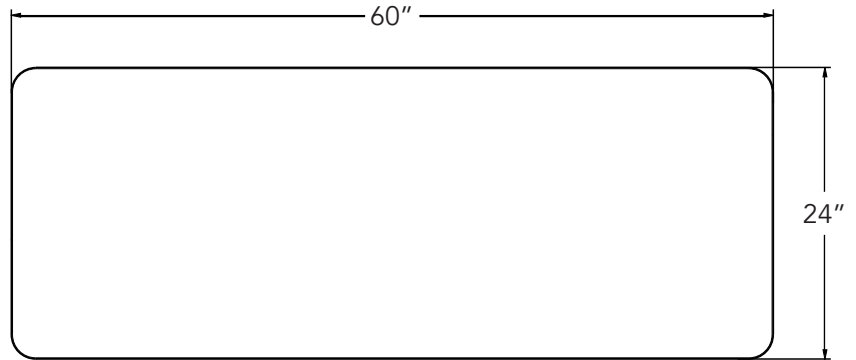



**OVERVIEW**

The Agree Table was created to support the evolving needs of upper-grade classrooms, CTE spaces, and higher education environments. As instruction becomes more collaborative, technology-rich, and student-driven, the Agree Table provides a clean, professional foundation that adapts to how learning happens today, while signaling a more adult, high aesthetic experience for students.

**MATERIALS**

High-pressure laminate (HPL) worksurfaces are 1-1/8" (30mm) nominal finished thickness and feature balanced construction to prevent bowing or warping, with 0.028 inch (.71mm) thick high-pressure laminate on the top surface and a resin backer on the bottom. The particleboard wood core is 45 lb/cu ft (720.8 kg/cu m) density. The laminate and backer are permanently attached with PVA adhesive and reinforced under pressure to the wood core. 1/8" (3mm) thick plastic edgeband is applied to the entire perimeter of the worksurface to prevent any outgassing from exposed wood core. T-mold also available.

Formed tubular steel leg is 1-1/2" (40mm) dia. x 13 ga. (.095" or 2mm nom.) welded to a 5-1/2" (140mm) x 6-1/16" (154.5mm) mounting plate of 3/16" thick (4.7mm) thick steel. Optional 3" (68.6mm) dual wheel swivel casters.

**AGREE TOP & EDGE PROFILE**

1 1/4" TOP W/ BUMPER T-MOLD  
NO LETTER TO FOLLOW MODEL NO.

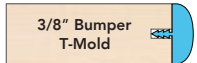

1 1/4" TOP W/ 4MM T-MOLD  
D

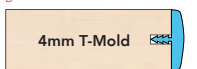

1 1/4" TOP W/ 3MM - 90° CORNERS  
H

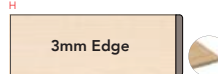

1 1/4" TOP W/ 3MM - ROUND CORNERS  
F



**DIMENSIONS**

Model	Description	D"	W"	H"
02510	30"x48" Rectangle Table	30	48	28.5
02510F	30"x48" Rectangle Table w/ 3mm Edgeband	30	48	28.5

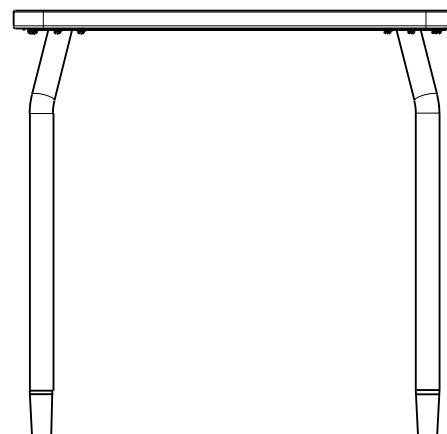
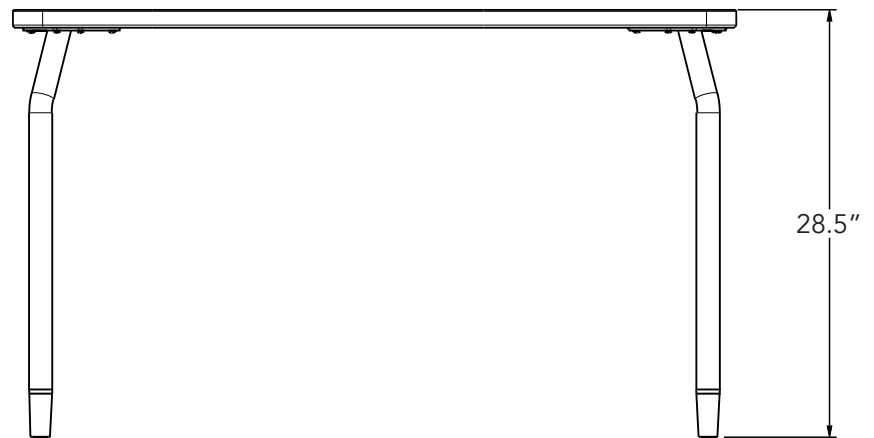
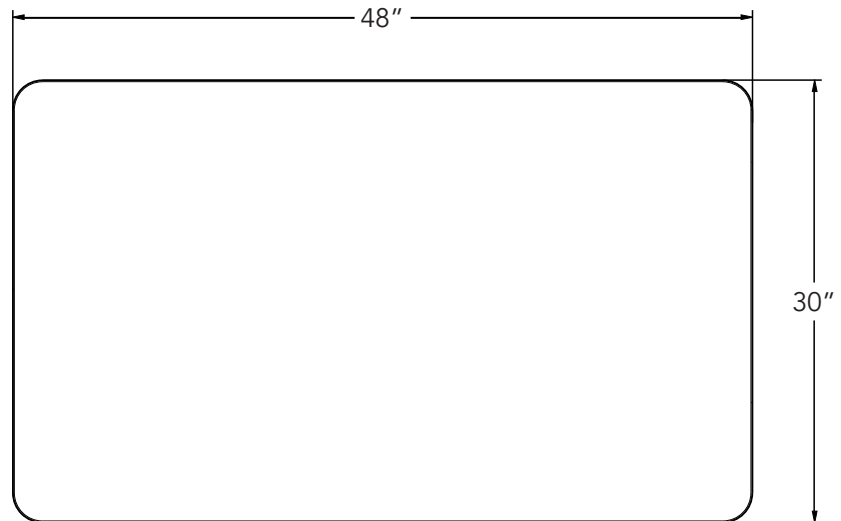



**OVERVIEW**

The Agree Table was created to support the evolving needs of upper-grade classrooms, CTE spaces, and higher education environments. As instruction becomes more collaborative, technology-rich, and student-driven, the Agree Table provides a clean, professional foundation that adapts to how learning happens today, while signaling a more adult, high aesthetic experience for students.

**MATERIALS**

High-pressure laminate (HPL) worksurfaces are 1-1/8" (30mm) nominal finished thickness and feature balanced construction to prevent bowing or warping, with 0.028 inch (.71mm) thick high-pressure laminate on the top surface and a resin backer on the bottom. The particleboard wood core is 45 lb/cu ft (720.8 kg/cu m) density. The laminate and backer are permanently attached with PVA adhesive and reinforced under pressure to the wood core. 1/8" (3mm) thick plastic edgeband is applied to the entire perimeter of the worksurface to prevent any outgassing from exposed wood core. T-mold also available.

Formed tubular steel leg is 1-1/2" (40mm) dia. x 13 ga. (.095" or 2mm nom.) welded to a 5-1/2" (140mm) x 6-1/16" (154.5mm) mounting plate of 3/16" thick (4.7mm) thick steel. Optional 3" (68.6mm) dual wheel swivel casters.

**AGREE TOP & EDGE PROFILE**

1 1/4" TOP W/ BUMPER T-MOLD  
NO LETTER TO FOLLOW MODEL NO.

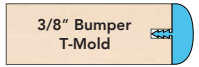

1 1/4" TOP W/ 4MM T-MOLD  
D

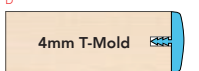

1 1/4" TOP W/ 3MM - 90° CORNERS  
H



1 1/4" TOP W/ 3MM - ROUND CORNERS  
F



**DIMENSIONS**

Model	Description	D"	W"	H"
02513	30"x72" Rectangle Table	30	72	28.5
02513F	30"x72" Rectangle Table w/ 3mm Edgeband	30	72	28.5

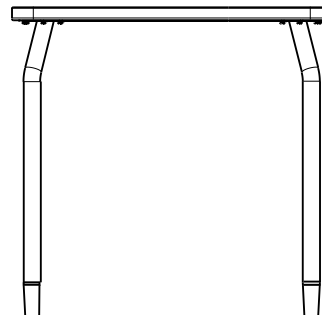
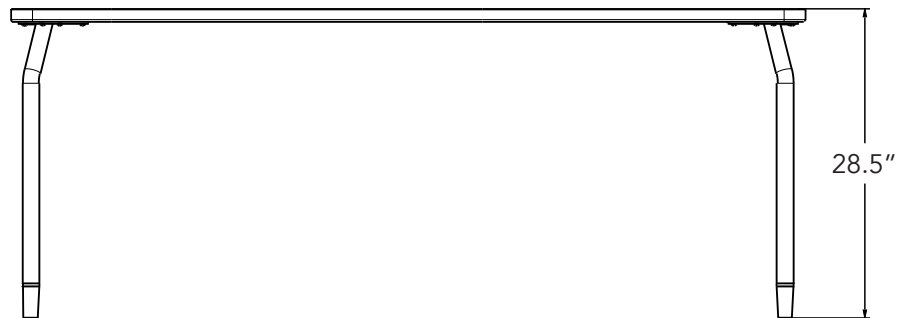
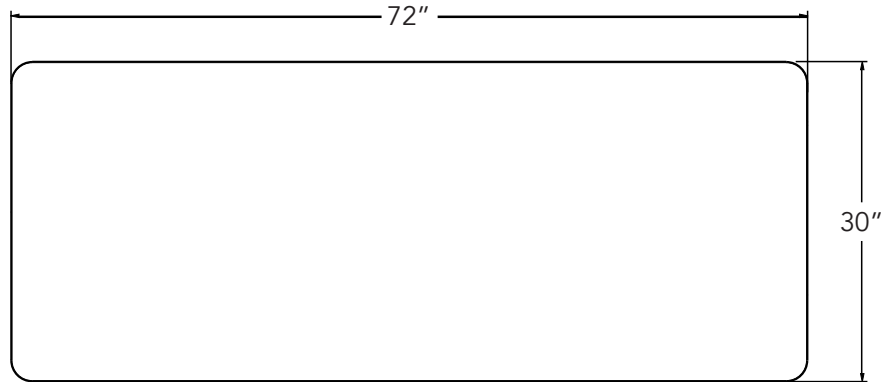

**STANDARD LAMINATE OPTIONS**

Want to specify a different laminate?

No problem. If you have 20 or more tops of the same color -60 or -38 there is no upcharge. Have 20 or less? We can quote for you with the Wilsonart code and finish style. We can specify other laminates – call to inquire and get a quote.



**SUGGESTED LAMINATE OPTIONS**

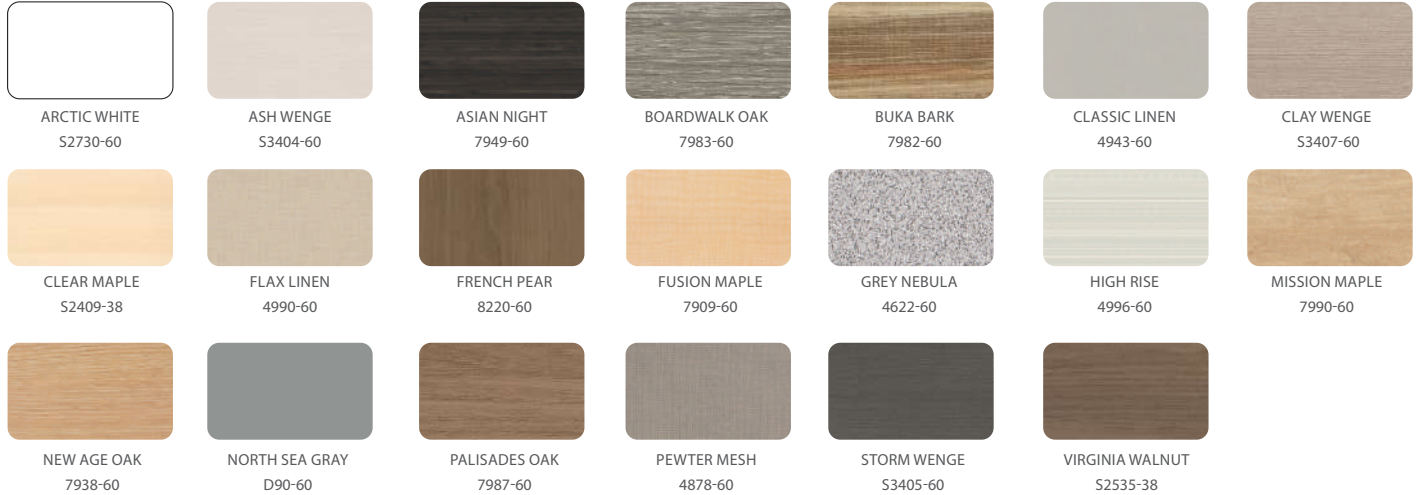

**STANDARD EDGE COLOR OPTIONS**



All 20 of the standard laminates are -60 finish, if you need to match a laminate from a previous year, please let us know on your order (example Pewter Mesh 4878-38, our standard is -60).

When the WilsonArt Laminate code includes a "Y", "K", "-12" "-78", "Aeon" etc, these are special laminates with an upcharge, even when it contains -38 or -60.

**EDGE COLOR OPTIONS WITH ADDITIONAL LEAD TIME**



**LEG COLOR OPTIONS**

